

# The Robert Sorby Modular Micro tool system

The Modular handled micro Sandmaster is just one of the products from the Robert Sorby Modular micro tool system. It is also available as a Modular micro Sandmaster which comes without a handle.

This quick and simple system allows the woodturner to utilise one handle with an array of tools. Just one of the Modular micro handled sets need to be purchased and then any of the Modular micro sets without handle can be added to it. By adjusting two locking screws in the handle, the tool can be interchanged from Sandmaster to turning tool and swan neck hollowing to Spiral system.

Other sets available are:

Modular Micro handled Spiral tool.

This Spiral tool has two small cutters which allows the woodturner to spiral and decorate any small project that demands fine detail and crisp design. When used on very close grain wood or man made materials this tool will enhance any turned project with fine delicate spirals or beautiful textured patterns.

Modular Micro handled Spindle set.

Comprising of a 1/2" (13mm) gouge, a 1/4" (6mm) skew and a 5/32" (4mm) Beading and parting tool the Spindle set gives the woodturner the tools needed to produce beautiful intricate turned pieces.

Modular Micro Handled Hollowing set

When used in conjunction with the Spindle set to produce the exterior of small intricately detailed shapes, the Hollowing set can be used to remove all the waste material from inside.

The boring tool will remove a lot of waste material very quickly, this will allow the swan neck tool in to produce fine hollow pieces such as vases. The 1/4" (6mm) round nose scraper will allow the exterior of the piece to be finished .

All of the above sets, Sandmaster, Spiral, Spindle and Hollowing are available as Modular Micro sets without handles.

Available at all Robert Sorby stockists.

*Robert Sorby*

Athol Road, Sheffield, England S8 0PA. Tel: +44 (0)114 225 0700 Fax: +44 (0)114 225 0710

sales@robert-sorby.co.uk www.robert-sorby.co.uk

Registered in England: Company No 3464018, Registered office: Atlas Way, Atlas North, Sheffield, S4 7QQ. VAT No GB 172 4019 84

The Modular Handled Micro Sandmaster uses the same bearing type technology as the full size Sandmaster.

It utilises a 1" (25mm) sanding pad enabling it to access difficult to get at areas.

The head of the Micro Sandmaster can be set in the best position for the project to be sanded.

The sanding pad has a sponge section to allow it to blend into any curve and follow the shape of the project being sanded. The sponge also helps to dissipate any heat that may be built up from friction.

The Micro Sandmaster set includes two discs of each of four grades of abrasive 120, 180, 240 and 400 grit. By using these in order from coarse to very fine will ensure the surface of the wood is given a glass like finish.

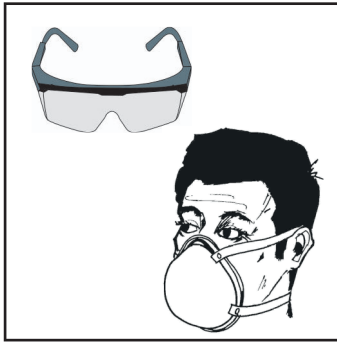

Always use eye protection and a form of dust mask as well as an air cleaner and dust extractor when doing any form of woodworking.

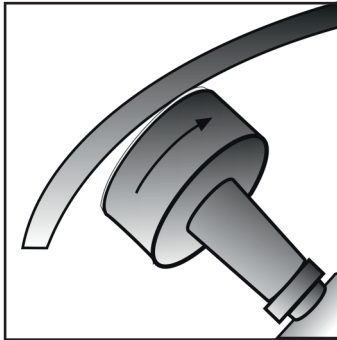

Allow the abrasive to lightly touch the surface of the wood to ensure it works at its optimum without generating excessive heat from friction.

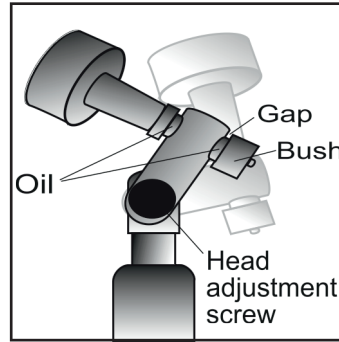

Always ensure that there is a slight gap between the bush and the main body. Regularly place a spot of oil on the bearing. Loosen the head adjustment screw, move the head to the required position and re-tighten.

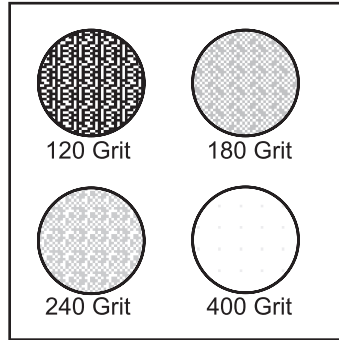

Start with the 120 grit medium coarse abrasive and then work through in number order up-to the fine 400 grit. This will ensure all scratches are removed and a glass like finish is achieved.

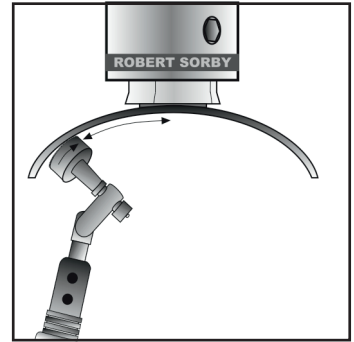

Touch the surface of the wood lightly to allow the abrasive disc to start rotating. Start the Sandmaster rotating on the outer edge of your work prior to moving into the slower moving middle section.

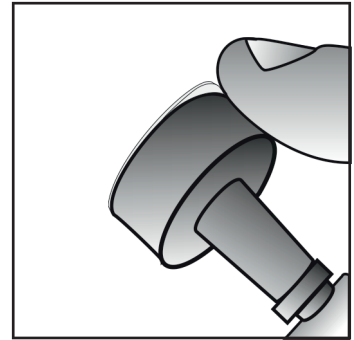

When removing the abrasive discs, place thumb over the edge to avoid damage to the sponge pad.